

ENERGYX

PORTABLE



ENERGYX PORTABLE USER MANUAL

V20231007

azzo.com

AZZO
technology comes together®

CONTENTS

1	ABOUT THIS MANUAL	3
2	SAFETY PRECAUTIONS	4
2.1	Symbols	4
2.2	EnergyX Portable safety precautions	5
2.3	Additional safety information	5
2.4	Hazard of electric shock, burn or arc flash	6
3	ENERGYX PORTABLE METER OVERVIEW	7
3.1	Kit contents	8
4	APPLICATION AND LIMITATION OF USE	9
4.1	Voltage limitations	9
4.2	Short-circuit breaking capability	9
4.3	Current measurement	9
4.4	Isolated network or neutral conductor not accessible	9
5	INSTALLATION AND SETTINGS	10
5.1	Pre-installation	10
5.2	Ending the installation period	11
5.3	General recording and communication philosophy	11
5.4	Current inputs	12
5.4.1	Installation of RCs	12
5.4.2	Busbar installation	13
5.4.3	Cable installation	13
5.5	Installing the portable unit and fuse box	14
5.6	Installing the cables	14
5.6.1	Connecting the voltage inputs	15
5.6.2	Fuse box to electrical panel	16
5.6.3	Fuse box to EnergyX Portable	17
5.6.4	Auxiliary power	17
5.7	Install modem antenna Modem status indicator LEDs	18
5.8	ION Meter custom settings	20
5.9	Remote verification and logging	21
5.10	Connection to remote energy management cloud-hosted server	22
6	SUPPORT CONTACT	23
6.1	Contact details	23
6.2	Supplier information	23
6.3	Manufacturer information	23
7	TECHNICAL DATASHEET	24
	APPENDICES	25
	APPENDIX A: Rogowski Coil Transducers	25
	APPENDIX B: Requirements for a locally acquired SIM	26
	APPENDIX C: How to set or change the combination of the EnergyX Portable lock	27

01 ABOUT THIS MANUAL

This manual discusses the features of the AZZO EnergyX Portable kit and provides installation instructions.

This manual assumes that the user understands power metering and is familiar with the equipment and power system in which the equipment will be installed.

02 SAFETY PRECAUTIONS

- **Local electrical safety requirements must be followed**
- **Use of personal protection equipment (PPE) as per recommendations is mandatory.**
- **Electrical safety barriers / prevention system must be put in place before leaving the area to prevent any access to live parts during the installation period**

2.1 SYMBOLS



The use of the shown danger/warning safety label indicates that an electrical hazard exists which will result in personal injury if the instructions are not followed.



This is the safety alert symbol. It is used to alert you to potential personal injury hazards. Obey all safety messages that follow this symbol to avoid possible injury or death.

2.2 ENERGYX PORTABLE SAFETY PRECAUTIONS

Installation, wiring, testing and service must be performed in accordance with all local and national electrical codes.

Prior to every use, it is advisable the cables and connectors be checked for damages (e.g., cuts, abrasions, crush points, etc.).

Should any components of the EnergyX Portable indicate heavy wear or damages, **contact AZZO for replacement components**. Damaged components should not be used.

Always use certified components and accessories.

A means of locking the yellow case is provided by AZZO. In the event the provided lock requires replacement, the replacement lock must be fit for purpose, and cannot be bypassed by the general public to maintain safety.

Carry handles are provided on both the yellow and black cases for easy transportation. Do not drop, as this will potentially lead to damages.

Please follow correct manual handling standards when transporting/lifting the AZZO EnergyX Portable kit.

2.3 ADDITIONAL SAFETY INFORMATION

Safety precautions must be followed before attempting to install and service the AZZO EnergyX Portable. Carefully read and follow the safety precautions outlined below prior to installation.

These safety precautions are for the nominated equipment only and are to be used in conjunction with any legislative or company related safety standards or requirements related to safe electrical work.

Electrical equipment should be installed, operated, serviced and maintained only by qualified personnel. **No responsibility is assumed by AZZO for any consequences arising out of the use of this equipment.**

A competent, qualified person is one who has the skills and knowledge related to the construction, installation, and operation of electrical equipment and has received safety training to recognize and avoid the hazards involved.

As Standards, specifications and designs change from time to time, please ask for confirmation of the information given in this publication.



2.4 HAZARD OF ELECTRIC SHOCK, BURN, OR ARC FLASH

- Only a licensed electrician should use this equipment. Installation should be performed only after reading this entire installation manual.
- Apply appropriate personal protective equipment (PPE) and follow safe electrical work practices. See NFPA 70E & CSA Z462, or applicable local Standards.
- NEVER work alone.
- Prior to installation, disconnect all sources of electric power to the distribution board where the works will be conducted. Assume that all circuits are live until they have been completely de-energised, tested, locked out and tagged out. Pay special attention to the design of the power system. Consider all sources of power, including the possibility of back-feeding, e.g., secondary power supplies, capacitor banks, etc.
- De-energise all power supplying this equipment before working on or inside it.
- Always use an appropriately rated voltage sensing device (e.g., multimeter) to verify that all power is off.
- Beware of potential hazards, wear personal protective equipment, carefully inspect the work area for tools and objects that may have been left inside the equipment.
- Use caution while removing or installing panel covers so that they do not extend into the energised bus; avoid handling the panels, which could cause personal injury.
- The successful operation depends upon proper handling and installation of the EnergyX Portable and related equipment.
- Neglecting fundamental installation requirements may lead to personal injury as well as damage to electrical equipment or other property.
- Prior to performing any insulation testing (e.g., a Megger test) on any equipment in which the power quality meter is installed, disconnect all input and output wires to the power quality meter. High voltage testing may damage electronic components contained in the power quality meter.
- The Rogowski Coils are NOT current transformers, do not short out the transducers.
- Do not open the yellow EnergyX Portable case while energised.
- Do NOT make any adjustments or use a tool inside the yellow EnergyX Portable box while energised.
- Ensure all measuring cables (current or voltage) are protected from damage during the recording session, especially if the cables need to protrude through the escutcheon (inner door) or door.
- Indoor use only, and protected from the weather.

03 ENERGYX PORTABLE METER OVERVIEW

The EnergyX Portable kit is a device used for energy and power quality audits, including active harmonic filter pre- and post-verification.



3.1 KIT CONTENTS

The EnergyX Portable Kit comprises of the following items:



- ① EnergyX Portable - ION7400 with integrated 3G/4G Modem
- ② 2x 3G/4G Modem Antennas (pre-connected right angle antenna, and one extension antenna with lead)
- ③ 3 Phase voltage reference fuse box
- ④ Voltage reference connection cable (3m length) to measuring panel
- ⑤ Voltage reference interconnection cable (1m length) to power meter (yellow box)
- ⑥ 5x Dolphin/crocodile clamps for voltage references
- ⑦ 5x Ferruled & 5x 10mm diameter ring crimp connectors for voltage references
- ⑧ 4x Phoenix Contact Rogowski Coils (190mm diameter - 4000A max)
- ⑨ 4x Busbar Rogowski Coil bare bus mounts
- ⑩ QR token on EnergyX Portable travel case for installation video instructions
- ⑪ QR token on EnergyX Portable flip cover for connectivity and installation verification
- ⑫ IEC socket power supply cable (as appropriate to the country type).

IEC socket includes a 4A fuse. Voltage reference fuse box includes 4A fuses



04 APPLICATION AND LIMITATION OF USE



4.1 VOLTAGE LIMITATIONS

- The AZZO EnergyX Portable is capable of WYE or DELTA connections, single or three phase (voltage reference). If single phase or delta, the appropriate setting must be set (default is 3P WYE). Contact AZZO for further information.
- Should the applied auxiliary voltage (via the IEC plug) be lower than 110 VAC L-N, the EnergyX Portable will not energise. The IEC lead must be plugged into a 100-250 VAC 50/60Hz L-N power point/receptacle. Maximum auxiliary voltage is 250V AC.
- If the system voltage is greater than the specified direct connect maximum reference voltage (690V AC), you must use voltage (potential) transformers (VTs/ PTs) to step down the voltages connected to the voltage references on the meter.

4.2 SHORT-CIRCUIT BREAKING CAPABILITY

- Short circuit current rating of the upstream fuse/breaker must be taken into consideration. The 4A fuses in the fuse box as provided are rated to 120kA interrupt rating. Coordination must be considered on all installations to ensure no more than 120kA fault current is potentially available at the AZZO fuse box otherwise damages could occur, or risk to life.

4.3 CURRENT MEASUREMENT

- Primary max current should not exceed 4000A at primary side, otherwise erroneous readings will occur.
- Rogowski coil insulation is limited to 80°C (176°F) and 1000 VAC, therefore the cables must not touch bare busbar.
- Connection on MV (medium voltage) isolated cables is possible providing the insulation is respected.

4.4 ISOLATED NETWORK OR NEUTRAL CONDUCTOR NOT ACCESSIBLE

- Installation on isolated networks or networks where the neutral conductor is not accessible will still require an available socket/power point for the IEC male plug. A **neutral is mandatory for the EnergyX Portable to be powered up.** In this application it is suggested, but are not limited to, the use of an appropriate generator or UPS to power the EnergyX Portable for the period of the hire on site.

05 INSTALLATION AND SETTINGS



- Failure to follow these instructions may result in death or serious injury.
- It is recommended the installation and removal of the EnergyX Portable be done whilst circuit is de-energised whenever possible.
- A safety assessment must be performed by authorised personnel. All relevant Personal Protection Equipment (PPE) must be in place to ensure all safety standards and processes are followed.

5.1 PRE-INSTALLATION

- It is critical the installer inspect all accessible components of the EnergyX Portable kit for visual wear and damages.
- Should there be any damages, if no replacement component(s) is available, the installation is not to proceed: AZZO must be contacted.
- Ensure the SIM card is provided and installed and tested prior to site installation. *Refer to Appendix B.*
- Change and record the lock code on the yellow case. *Refer to Appendix C.*

GENERAL INSTALLATION ARRANGEMENT – EXAMPLE

A typical installation arrangement:

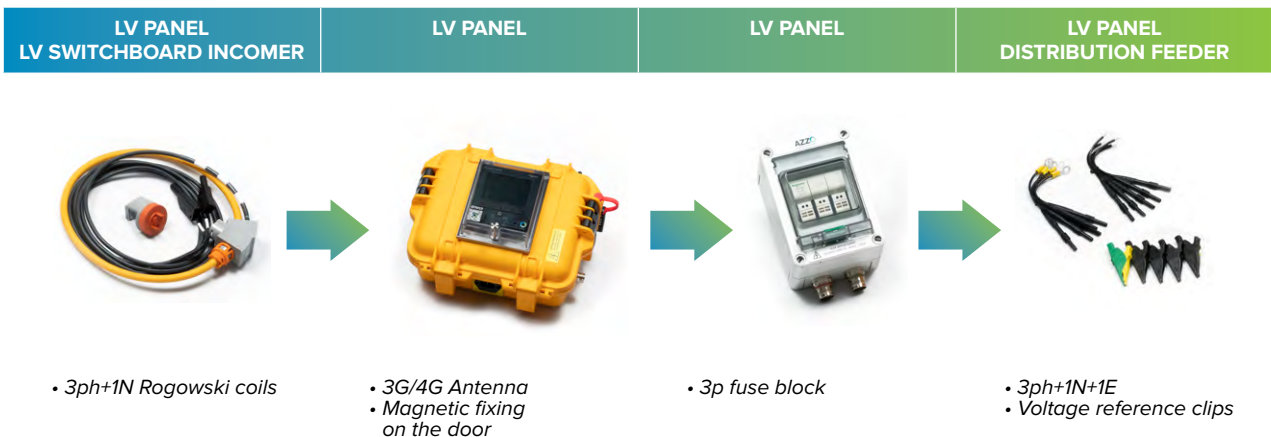

5.2 ENDING THE INSTALLATION PERIOD

- It is critical the installer inspect all accessible components of the EnergyX Portable kit for visual wear and damages after the installation period.
- Should any damages occur during the recording session, all concerned components must be replaced.
- All components must be accounted for.
- In case of missing parts, AZZO must be contacted.

5.3 GENERAL RECORDING AND COMMUNICATION PHILOSOPHY

- In the event of communication loss, the Power Meter allows for approximately ninety (90) days of offline logging (FIFO). Once the EnergyX Portable is re-connected to the remote cloud server, the stored logs will be uploaded automatically.

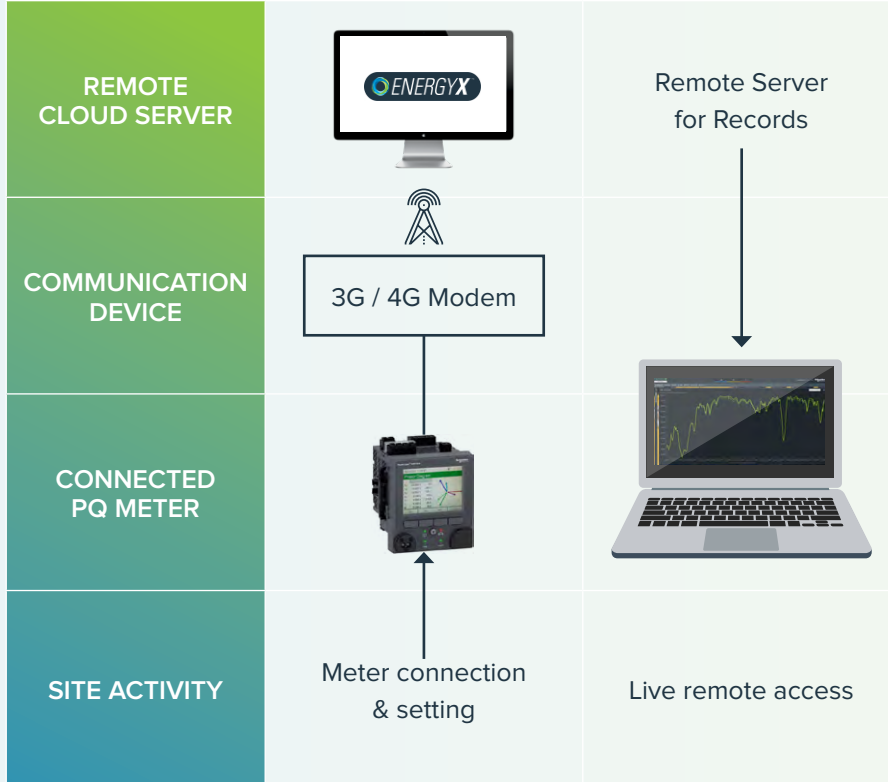

5.4 CURRENT INPUTS – ROGOWSKI COILS (RC)

5.4.1 INSTALLATION OF RCs

The Rogowski Coils (RC) are essential for the EnergyX Portable to capture all current-related information up to 4000A. Referencing Appendix A, set the transducers to the appropriate current range, and update the meter's ratios accordingly (p19). Please note the secondary cables on the RCs are 3m, which is important to keep in mind to determine installation location (along with the voltage reference cables and the IEC auxiliary power plug).



Each Rogowski Coil is phased/marked either with colours or white stripes that indicate their phasing. Please follow this convention when installing the Rogowski Coils and plugging into the appropriate port on the side of the meter.

- Phase A/L1 – 1 stripe
- Phase B/L2 – 2 stripes
- Phase C/L3 – 3 stripes
- Neutral – 4 stripes

NOTES

SHAPE VS ACCURACY

When installing the RCs, it is acceptable that the coils themselves not to maintain a round shape which could be due to a congested switchboard, however it is advisable to install the RCs in a manner that does not cause unnecessary stress to the coil itself. The RC error will typically maintain less than 1% irrespective of primary cable/bus bar position.

CURRENT FLOW ARROW

The direction of current flow must be observed: the grey arrow on the housing head must follow the direction of current flow, failure to follow this will result in erroneous readings.

RC CONNECTION

If not all the RCs are used, e.g., single phase applications, **all the RCs still must be installed into the female banana sockets on the EnergyX Portable.** Failure to comply will result in “ghost” readings on the meter.

ROGOWSKI COIL

The RCs come with black 3m leads. These leads must not be coiled up while the EnergyX Portable is energised to reduce an antenna effect on the secondary of the RCs.

For details on transducer configuration, refer to Appendix A (page 24).



Current flow arrow



RC connection

5.4.2 BUSBAR INSTALLATION

Use the provided bare busbar mounts if the RCs must clip onto bare bus to assist with ensuring the Rogowski Coils (and associated cables) **do NOT touch the bare busbar/cable**. Refer to below instructions:

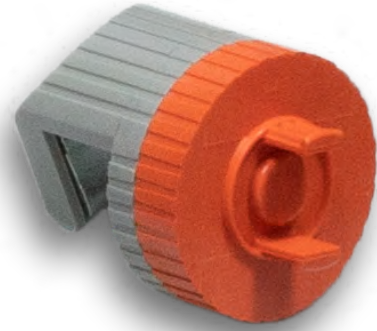

1. Place the power rail holder onto the top edge of the power rail, making sure that it is straight.
2. Turn the thumbwheel to the right (hand-tight) and make sure that the holder is firmly attached to the power rail.
3. Turn the bayonet locking of the Rogowski coil to the left (to release the measuring line).
4. Pull the coil line out of the housing.
5. Route the coil line around the power rail.
6. Push the flange of the coil housing onto the two guide ribs of the thumbwheel until the limit stop is reached.
7. Push the coil line into the housing.
8. Turn the bayonet locking to the right until you hear the measuring coil click into place.
9. Make sure that the signal line does not touch any of the power rails, since the **maximum permitted temperature is +80°C (176°F)**.
10. If necessary, turn the housing to the right in 15° steps (only turn it to the right or else the thumbwheel might become loose).
11. Connect the signal line of the Rogowski coil to the input current terminals of the EnergyX Portable.
12. Make sure that the signal line does not touch any of the power rails, since the **maximum permitted temperature is +80°C (176°F)**.
13. The back flange is 6mm thick, which needs to be kept in mind for spacing between the bus bars. The bus bar clamps are designed for 5-10mm (extra accessory) or 10-15mm (provided) depending on which clamps you have. Once the clamps are installed and secure, attach the respective Rogowski Coils to the clamps.
14. Reminder: Initial installation of busbar clamps must be secured only on de-energised busbars.

The back flange is 6mm thick, which needs to be kept in mind for spacing between the bus bars. The bus bar clamps are designed for 5-10mm (extra accessory) or 10-15mm (provided) depending on which clamps you have. Once the clamps are installed and secure, attach the respective Rogowski Coils to the clamps.

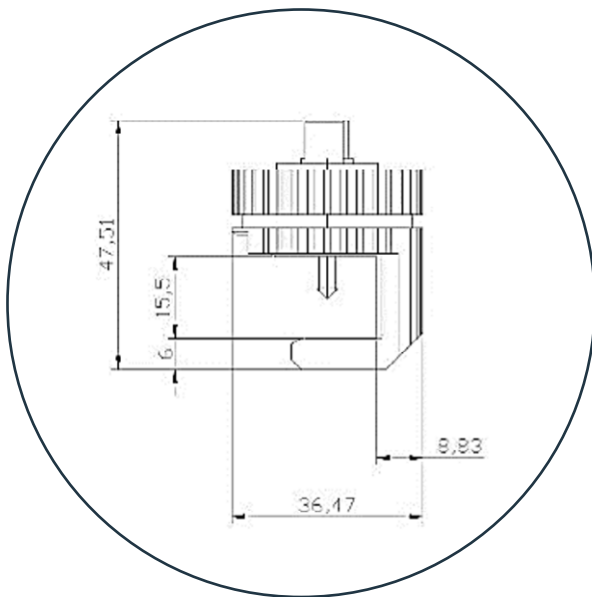

5.4.3 CABLE INSTALLATION

If the clamps are not being used, ensure zip/cable ties are used through the slots on the Rogowski Coils to secure the cables in place, perpendicular (as reasonably practical) to the Rogowski coil.

Reminder: Initial installation of busbar clamps must be secured only on de-energised busbars.



5.5 INSTALLING THE PORTABLE UNIT AND FUSE BOX

It is recommended that a pre-site visit and safety assessment is conducted to determine the suitability and location of the installation of the AZZO EnergyX Portable meter(s).

The maximum approximate distance from the voltage reference to the meter is 4m, and the RC (Rogowski Coils) secondary leads are 3m in length.

It is recommended the EnergyX Portable and fuse box both be placed on a stable flat surface when in use. The units should not be located in a high-traffic location due to public interference, and accidental knocking of units, which can result in damages.

It is the installer's responsibility to ensure the application suits the design requirements of the EnergyX Portable, and no fault is accepted by AZZO should any damages occur from correct or incorrect installation.

5.6 INSTALLING THE CABLES

It is critical the qualified electrician takes careful consideration during and after installation of all cables/connectors associated with the EnergyX Portable install. Failure to consider the phasing and connection points could result in incorrect data, damages, injury, or death.

Depending on location and duration of the logging period, it is suggested the electrician makes the necessary intrusions into the site panel/box and provide necessary glands to prevent conductor damage and accidental access by non-authorized personnel.





Connectors with
8mm ring crimps



Connectors with
ferruled ends



Dolphin/crocodile
clamps

5.6.1 CONNECTING THE VOLTAGE INPUTS

VOLTAGE RATING

The EnergyX Portable has an IEC socket which requires a detachable mains supply cord (supplied) with suitable rating and certifications (e.g., ETL/UL). This is required to provide auxiliary power to the unit and must be rated accordingly (120-240 VAC 4-6A).

The voltage references are to be no more than 690V AC (100 VAC - 690 VAC).

CONNECTORS

All supplied connectors are to be used (fit for purpose) to obtain voltage reference to the EnergyX Portable through the provided fuse box.

Connectors with ferruled ends and/or 8mm ring crimps are provided to connect to banana ends for breakers, terminals, or screws/bolts as required.

Dolphin/crocodile clamps are also provided, and to be used at the installing electrician's discretion only. These clamps are only to be used where no other option is available. Other options are considered to be safer and more stable during installation and use.



5.6.2 FUSE BOX TO ELECTRICAL PANEL

1. Using the 3m multicore lead, plug the ring-coded connector into the fuse box or direct into the EnergyX Portable if the fuse protection is not required based on upstream protection of the 3m lead and associated hardware.



2. Connect the loose banana sockets into the appropriate connectors. These connectors/clamps are to be used on existing spare/available breakers in the panel using the provided ferruled ends or ring crimps.

Alternatively, the dolphin clamps are available for use as appropriate.

It is advisable the connections are done while both the circuit and provided fuse box are in the open state (de-energised).



3. The fuse box must be easily accessible to allow for easy isolation of the EnergyX Portable voltage reference. Alternatively, if a site infrastructure breaker is used as the voltage reference point, it can be used as a disconnection means for the voltage reference if easily accessible.

5.6.3 FUSE BOX TO ENERGYX PORTABLE

Using the 1m multicore cable, connect the provided ring-coded connector leads from the fuse box to the EnergyX Portable as identified on the right side of the unit means of obtaining voltage reference to the EnergyX Portable as identified on the right side of the unit.



5.6.4 AUXILIARY POWER

- i. An IEC male plug point has been provided on the bottom of the unit. Using the provided (or equivalent) IEC plug, this will need power from a 110-240 VAC (L-N) source through a receptacle/power point. This IEC plug is required to provide power to the EnergyX Portable unit.
- ii. The power point/receptacle the IEC cable plugs into must have a protective earth which must always be connected to an appropriate earth point to ensure safety.



5.7 INSTALL MODEM ANTENNA

Ensure antenna is securely tightened/connected. Failure to attach the antenna to the female connector on the top-right side of the unit will not allow remote access.

To ensure good 3G/4G network coverage, please ensure your cellular phone has good signal connectivity in the location where the EnergyX Portable is to be installed, as this will provide a guide as to the likelihood of remote connectivity.

A second antenna is provided should the 3G/4G coverage be limited. In addition, another suitable SMA connected antenna may be used that is fit for purpose should neither of the provided antennas provide for the 3G/4G coverage.

Please note that the AZZO EnergyX Portable is designed to provide for approximately three months of logging (based on standard logging parameters; high speed logging can be enabled, however this will reduce the onboard logging time and possibly affect the Telco plan requirements) locally should this be required for a standard application where 3G/4G signal quality is not available.

For instructions on APN setup for remote SIMs, refer to Appendix B (page 25).

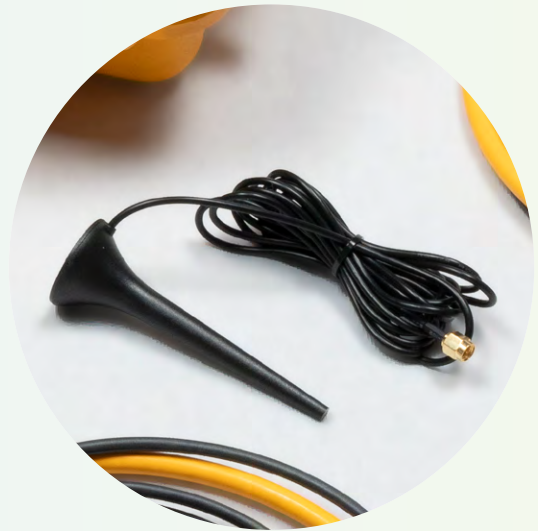

DIGI MODEM STATUS INDICATOR LEDS

Service LED:

No cellular service	●
Establishing PPP connection	☀
Connected	● (blinking)

Signal LED:

Poor or no signal	●
Fair signal	●
Good signal	●

Power LED:

Off: No power	●
Green: Powered	●





INHAND MODEM STATUS INDICATOR LEDS

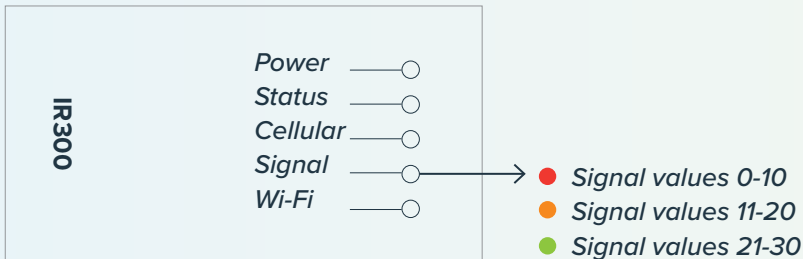

Power ●	Status ●	Cellular ●	Definition
Off	Off	Off	No Power
On	Off	Off	System Fault
On	On	Off	Module or SIM Card not identified
On	On	Flash	Connecting
On	On	On	Connected

5.8 METER CUSTOM SETTINGS

Custom settings are required on most installations due to the versatile nature of the EnergyX Portables. It is critical only the suggested changes stated in this manual are followed, any other changes not identified could cause erroneous data to occur. The suggested parameters that may require changing are:

1. CT (RC) primary ratios (incl. neutral)
2. Nominal current setting – match CT primary (incl. neutral)
3. PT/VT ratios
4. System type (delta/wye) & nominal voltage
5. System type (e.g., delta/wye) & nominal voltage
6. Nominal frequency (50/60Hz) – should only need to be set once

The factory default password to make the above changes is "1234" unless otherwise communicated by AZZO.

EXAMPLE: PT/CT SETUP

For all EnergyX Portable meters that include the IEC plug for auxiliary power, installation on VT/PTs is acceptable. The meter will need to have its settings adjusted to match the VT/PT ratios, otherwise the readings will be incorrect. This can be accomplished by going to the setup screen, then go to the volts mode:

- In the **Volts Mode** screen, press to go to the **PT/CT Setup** screen.
- In the **PT/CT Setup** screen, press to highlight the potential transformer
- (PT) or current transformer (CT) value for editing. Press to edit the highlighted value.
 - ▶ The CT ratio should match the transducer dip-switch settings per Appendix A (page 24).

NOTE: If you have exceeded the password timeout period, you are prompted to enter your meter's display password.

- Press to change the value of the highlighted digit (0-9). Press to go to the next digit. Press to enter the new value.
- When the confirmation screen is displayed, press to confirm the new value or to revert to the original value.



For details on transducer configuration, refer to Appendix A (page 24).

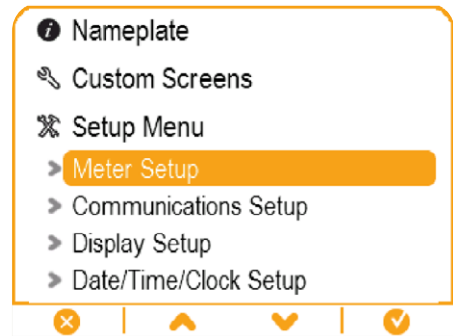

PT/CT Setup

	Primary	Secondary
PT	120.00	120.00
CT	5.000	5.000
4 CT	5.000	5.000



5.9 REMOTE VERIFICATION AND LOGGING

Once all the above steps have been accomplished, and all doors, escutcheons, etc have been re-installed and safety checks complete, re-energise the board and the breaker on the provided breaker box to energise the EnergyX Portable. It will take 5-10s for the unit to fully initialise.

Once powered on it is important to use the HMI interface to verify the installation. It is advisable to refer to the vector diagram on the HMI to verify the installation.



1. Select Power Quality

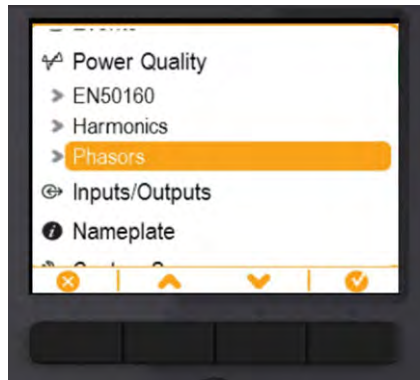

2. Select Phasors

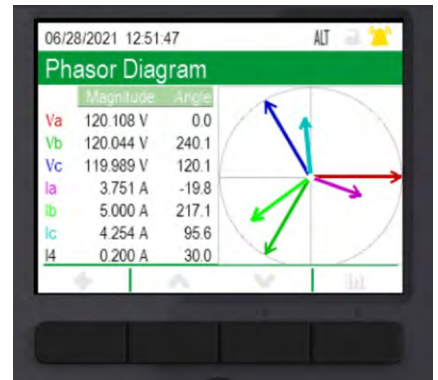

3. Review Phasor diagrams

Once done, scan the QR code on the EnergyX Portable flip cover and scan with your phone. Enter in the login details as provided by AZZO, and check that the information is current to ensure remote logging is active and accurate.



4. Scan QR code with phone

5. Log in to EnergyX

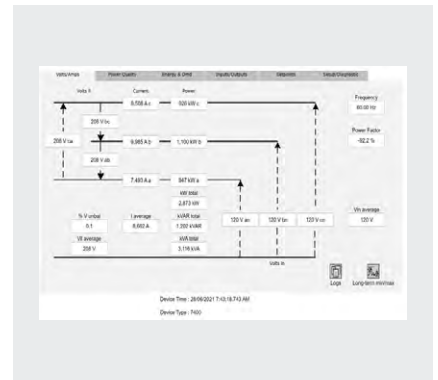

6. View live information

It is also advisable to independently verify the installation by using a clamp meter where it is safe to do or using an existing energy meter/breaker where the live current readings can be reviewed against the EnergyX Portable.

Once local verification is complete, remote verification is advisable and information recorded to provide for clear record keeping on the success of the installation.

5.10 CONNECTION TO REMOTE ENERGYX SERVER

Access to EnergyX Portable remote server:
portable.azzoenergyx.io.

Username and password will be provided.

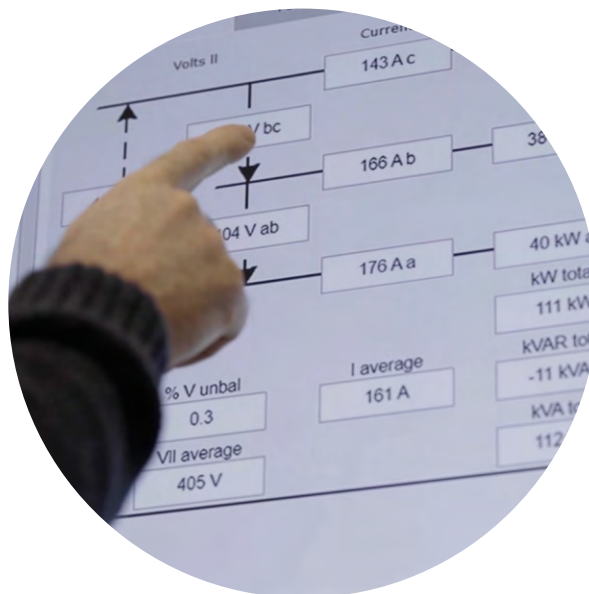



06 SUPPORT CONTACT

6.1 CONTACT DETAILS

TECH SUPPORT
helpdesk@azzo.com

SALES
energyxportable@azzo.com

6.2 SUPPLIER INFORMATION

GLOBAL:
AZZO Pty Ltd
B22, 6 MAB Eastern Promenade,
Tonsley, South Australia, 5042
Australia
+61 (1)300 00 AZZO (2996)

AMERICAS:
AZZO USA
330 Changebridge Road
Suite 101
Pine Brook, NJ 07058
USA
+1 973 575 5032

6.3 MANUFACTURER INFORMATION

AZZO Pty Ltd
B22, 6 MAB Eastern Promenade,
Tonsley, South Australia, 5042
Australia
+61 (1)300 00 AZZO (2996)

07 TECHNICAL DATASHEET

Operating Temperature:	-20 to 40°C (-4 to 104°F)
Humidity:	5 % to 95 % non-condensing. The EnergyX Portable and its components are for indoor use only
Cables and voltage clamps insulation	CATIII 600 VAC
Twist-lock connectors (voltage reference)	Max current: 6A
Stackable banana connectors (voltage reference)	Max current: 15A
Dolphin clamps (voltage reference)	Max current: 30A
Rogowski clamp insulation level	1000 VAC
Rogowski Coil current rating RC min/max	10..4000A
Rogowski Coil frequency measuring range	40... 20,000 Hz
Rogowski Coil operating temperature range	-30°C...80°C (-22°F...176°F)
Measuring Voltage range	100 VAC – 690 VAC
Auxiliary Power	120/230 VAC ±10%, 72W
Immunity to fast transients	EN 61000-4-4
Immunity to surge voltage load (surge)	EN 61000-4-5
Pollution degree	2
Protection against short circuits on measuring voltage circuits	Voltage Reference: 3 Pole, 10x38mm 690 VAC, 4 Amp, 120kA Auxiliary Power: 2 Pole, 5x20mm 250 VAC, 4-6 Amp, 1.5kA
Max altitude:	2000m above sea level
EnergyX Portable compliance:	CE certified to the following Standards: EN / IEC 61010-1:2010, AMD1:2016 and EN / IEC 61010-2030:2017 North American ETL certification to the following Standards: CAN/CSA-C22.2 No. 61010-1-12, UL-61010-2-030, UL-61010-1, CAN/CSA-C22.2 No. 61010-2-030 All critical components UL listed
	
Yellow Case dimension:	Exterior Length: 30.0cm (12") Exterior Width: 24.9cm (10") Exterior Depth: 12.0cm (5")
Yellow Case weight:	3.5kg/8lb (with components)
EnergyX Portable kit weight & dimension:	13kg/29lb (with all components) 54cm x 44cm x 30cm (20" x 17" x 12")

ROGOWSKI COIL TRANSDUCERS

i. ROGOWSKI COIL TRANSDUCER CONFIGURATION

Fully de-energise the EnergyX Portable. Unlock and open the yellow case (default code 000 – See Appendix C).

The EnergyX Portable includes four Rogowski Coils (RCs) that provide mV signals back to the transducers (internal to case) which in turn have dip switches that must be changed to suit the application (100, 250, 400, 630, 1000, 1600, 2000, 4000A) to ensure best accuracy (max 4000A). Only one dip switch is to be in the “on” position at a time per transducer unit.

For measuring current, you must put the DIP switches of the measuring range selected in the "ON" position.



Max measuring range	DIP switch	Max measuring range	DIP switch
100A	8	1000A	4
250A	7	1500A	3
400A	6	2000A	2
630A	5	4000A	1

ii. CONFIGURE RC RATIOS ON METER

Once the dip switches are changed, the “CT” (as shown on the HMI of the energy meter) ratios as well as the nominal current setting must also be changed accordingly via the HMI on the EnergyX Portable.

Though ideal to install around all parallel conductors per phase, if only some of them can be measured, then change the CT ratio to suit this in the context of the dip switches. E.g., 2000A with four conductors, and only two can be measured, then the meter setup ratio would be 4000/1A with the dip switch set to 2000A.

REQUIREMENTS FOR A LOCALLY ACQUIRED SIM

1. A standard data plan can be chosen (static or dynamic IP address, public or private) with at least 3GB of data per month using a nano SIM for the inHand modem.
 2. Be sure to note the APN settings for the new SIM card, and any username/password/PIN/PUK code that may be required.
 3. If the SIM has a PIN lock and/or a PUK code, please disable this first by inserting the SIM into a mobile phone and following the instructions from the Telco.
 4. Fully de-energise the EnergyX Portable. Unlock and open the yellow case (default code 000 – See Appendix C).
 5. Install SIM card using the instructions for InHand modems.
 6. Once the SIM card is installed, close the EnergyX Portable case and power on. After waiting approx. 2-3min, test connectivity by logging into EnergyX (see 5.9-5.10) and click on the “Diagram” tab to verify live results. If any connectivity issues* arise, check the LED lights per page 18. For further assistance, contact AZZO Tech Support (see 6.1).
- * Country-level telco providers may limit the VPN connectivity requirements, which will require AZZO remote support.

INHAND MODEM SIM INSTALLATION PROCESS

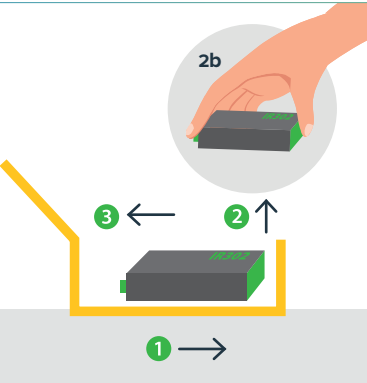
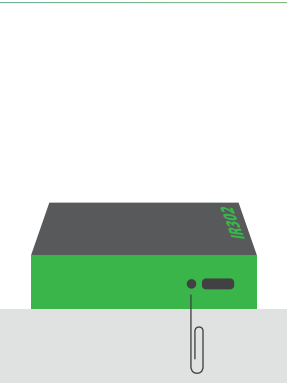
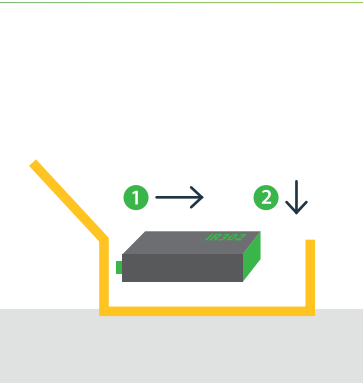
			
<p>On a flat surface, open case, and keep close to body to prevent the yellow case from moving around.</p>	<p>Gently remove modem</p> <ol style="list-style-type: none"> 1. Using both hands, pull the modem towards you. 2. While pulling towards you, gently lift up modem front with thumbs while pushing down on the back with fingers (2b). 3. To dislodge, push modem away from you and lift up. 	<p>Using a tool such as a paperclip, depress release and install SIM.</p>	<p>Re-install modem</p> <ol style="list-style-type: none"> 1. Angle back of modem down. 2. With modem on angle (ref step 2b), slide towards you, push down front of modem (should hear a "click"). 3. If modem is not secure, repeat above steps.

HOW TO SET OR CHANGE THE COMBINATION OF THE ENERGYX PORTABLE LOCK



1. Set the lock dials to the 0-0-0 position. DO NOT pull the shackle out.



2. Press the reset button using a tool, such as a ballpoint pen, until you hear a 'click'.



3. Set your desired combination by aligning the dials in the combination window.

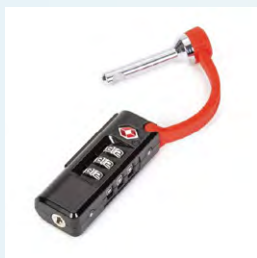

4. Pull the lock shackle out. The reset button will pop up, confirming the reset is complete.



To reset your lock, please set it to its current combination and then repeat the steps above.

